

# Data sheet

Saia® S Bus  
ALD1

## Single-phase bidirectional energy meter with integrated S-bus interface

Controls Division

Bidirectional energy meters with an integrated serial S-bus interface make it possible to read out all relevant data, such as energy, current, voltage, active and idle power and  $\cos\phi$ .

### Specifications:

- 1-phase energy meters, 230 VAC 50 Hz
- Direct metering to 32 A in both directions of current
- Display of the active power, voltage and current
- S-bus interface used to query data
- Idle power and  $\cos\phi$  available via the interface
- Up to 254 energy meters can be connected to a single S-bus interface.
- 7-digit LCD display for energy supply and feeding back
- Can be sealed with a sealing cap as an accessory
- Accuracy class B in accordance with EN50470-3, Accuracy class 1 in accordance with IEC62053-21

### Order number

Standard version: ALD1B5FS00A2A00

MID version: ALD1B5FS00A3A00

Sealing cap: 4 104 7420 0

### Technical data

Accuracy class	B in accordance with EN50470-3, Class 1 in accordance with IEC62053-21
Operating voltage	230 VAC, 50 Hz Tolerance $-20\%/+15\%$
Reference current/measuring current	$I_{ref} = 5\text{ A}$ , $I_{max} = 32\text{ A}$
Start current/minimum current	$I_{st} = 20\text{ mA}$ , $I_{min} = 0.25\text{ A}$
Power consumption	Active 0.4 W per phase
Meter range	00'000.00...99'999.99 100'000.0...999'999.9
Display	Backlight LCD, numbers 5 mm high
Pulses per kWh	LC display                      2000 pulses/kWh

### Assembly

Assembly	on 35 mm top-hat rail in accordance with EN60715TH35
Connections Main circuit	Max. conductor cross section 6 mm <sup>2</sup> , Pozidrive screwdriver size 1, flat-head screwdriver size 1 Torque: 1.2 Nm
Connections Control current circuit	Max. conductor cross section 2.5 mm <sup>2</sup> , Pozidrive screwdriver size 0 or flat-head screwdriver size 1 Torque: 0.5 Nm
Insulating properties	4 kV / 50 Hz test in accordance with VDE0435 for energy meters  6 kV 1.2 / 50 $\mu\text{s}$ overvoltage in accordance with IEC255-4  2 kV / 50 Hz in accordance with VDE0435 for interfaces  Device protection class II
Ambient temperature	$-10\text{ }^\circ\text{C} \dots +55\text{ }^\circ\text{C}$
Storage temperature	$-30\text{ }^\circ\text{C} \dots +85\text{ }^\circ\text{C}$
Relative humidity	95 % at 25 $^\circ\text{C} \dots +40\text{ }^\circ\text{C}$ , without condensation
EMC/resistance	Surge voltage in accordance with IEC61000-4-5 at the main circuit, 4 kV at the S-bus interface, 1 kV  burst voltage in accordance with IEC61000-4-4, at the main circuit, 4 kV at the S-bus interface, 1 kV  ESD in accordance with IEC61000-4-2, contact 8 kV, air 15 kV

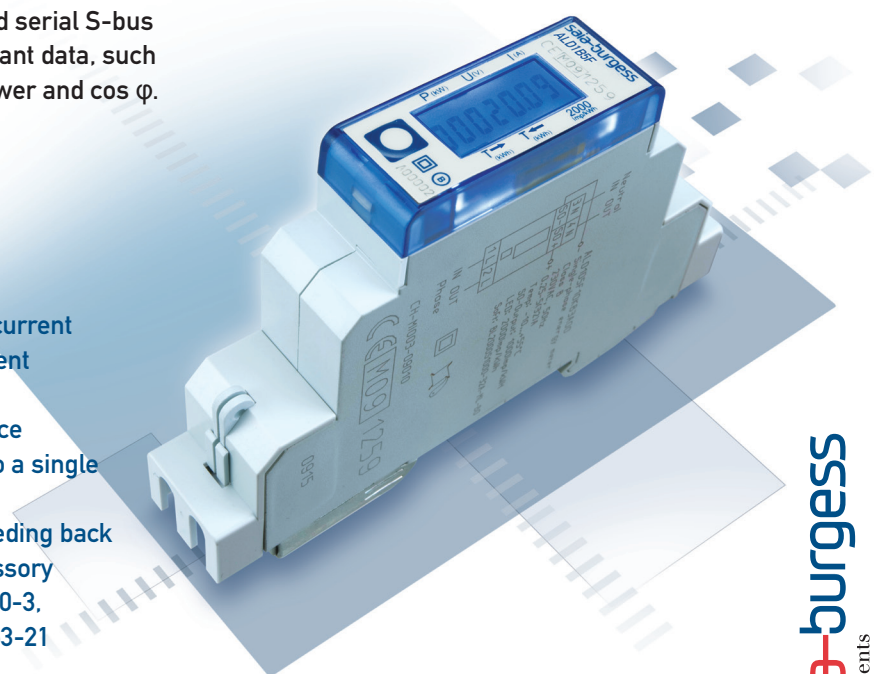

## Dimension drawings

### Architecture

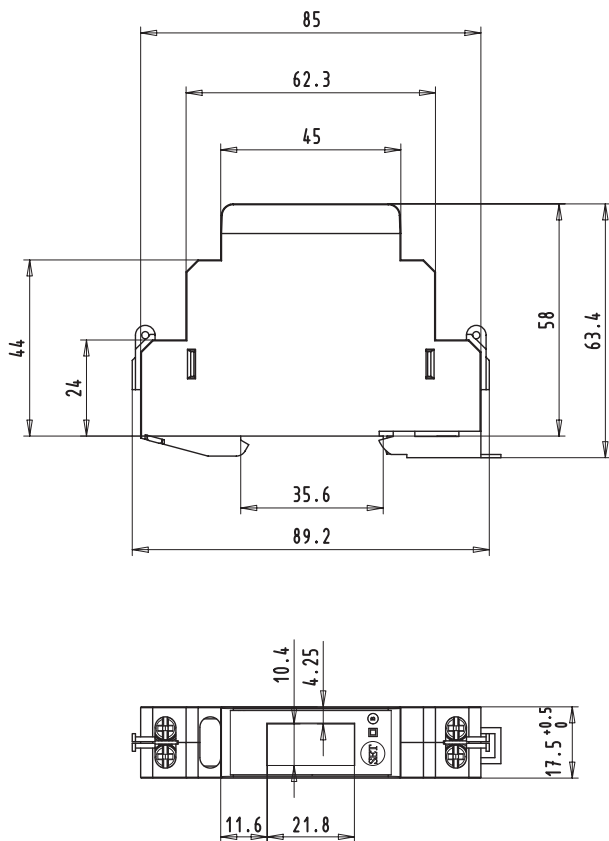

## Display components, direct measurement

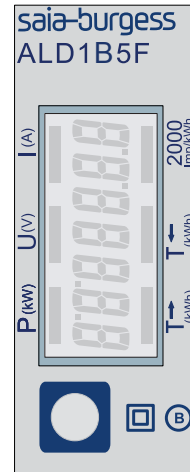

- T  $\rightarrow$  (kWh) Shows the total consumption  $\rightarrow$
- T  $\leftarrow$  (kWh) Shows the total feeding back  $\leftarrow$
- P (kW) Shows the present power  
current  $\leftarrow \rightarrow$  = reference (P positive)  
current  $\leftarrow \leftarrow$  = feeding back (P negative)
- U (V) Shows the voltage
- I (A) Shows the current
- 2000 pulses/kWh Pulses in accordance with the supplied power.

# Menu used to display the values on the LCD display

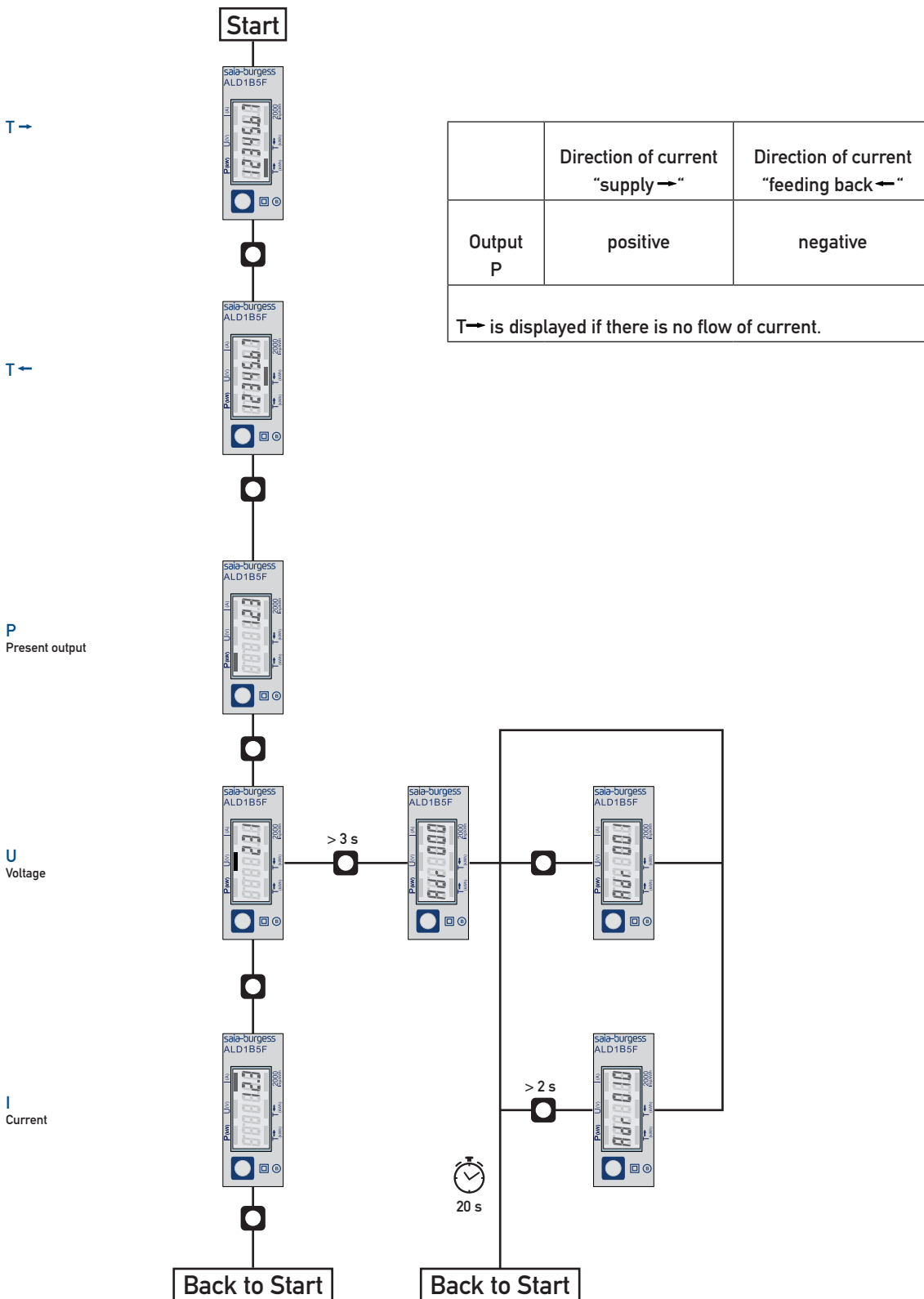

## Connection diagram

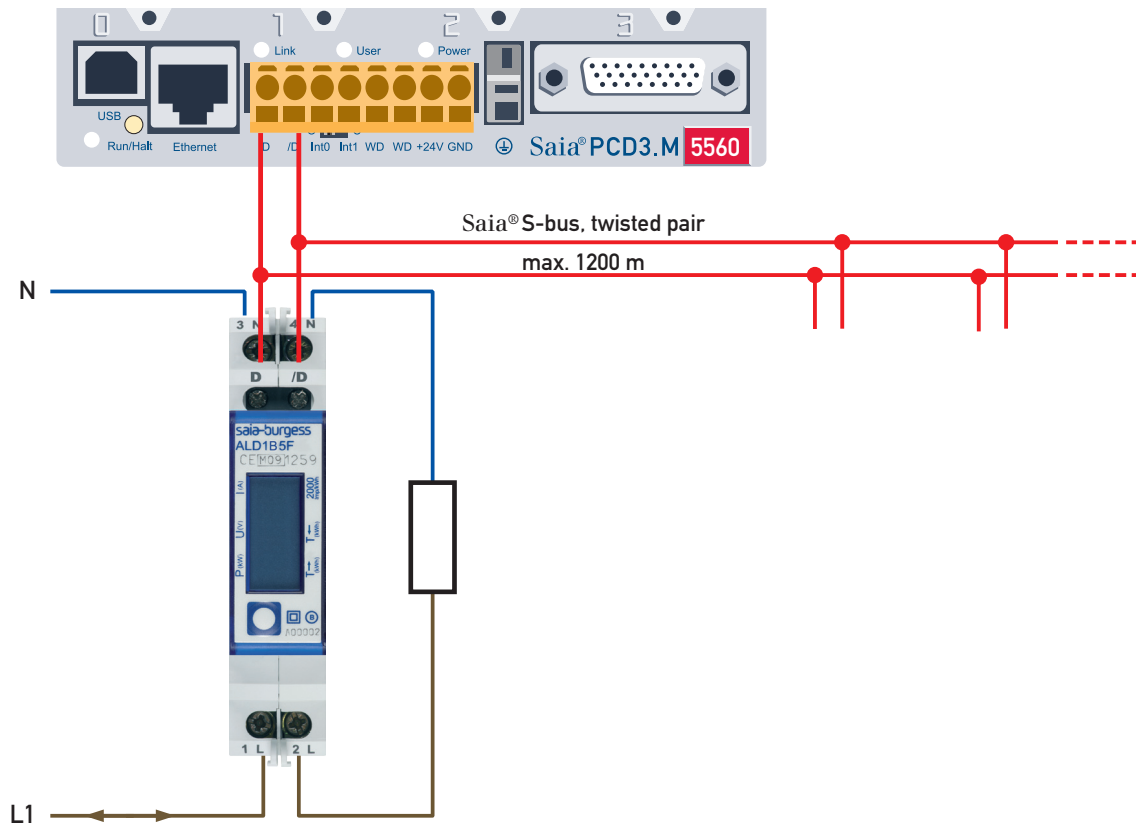

## Technical data S-bus

Bus system	Saia® S-bus
Transmission rates	2,400-4,800-9,600-19,200-38,400-57,600-115,200. The transmission rate is detected automatically.
Transmitting mode	Data
Bus length (max.)	1200 m (without repeater)
Response time:	Writing: Up to 60 ms
(system response time)	Reading: Up to 60 ms

- Communication is ready 30 s after activation
- Energy meters in a bus system with high data volume can result in performance losses in the bus
- Data are updated every 5 s. For this reason, an energy meter's query interval should not be shorter than 5 sec.
- 254 devices can be connected to the S-bus. If there are more than 128 devices, a repeater should be used
- The interface has no terminating resistance, this should be provided externally
- The registers being used are explained in the register list

## Data transmission

- Only «read/write» register commands are recognised.
- Only one register can be written at a time.
- The device returns an «NAK» if more than one register is written at the same time.
- Up to 10 registers can be read at the same time.
- The device returns an «NAK» if more than 10 registers are read at the same time.
- The device will not respond to unknown queries.
- The device has a voltage monitor. The registers are saved in the EEPROM (transmission rate, etc.) if there is a drop in voltage

## Changing the device's S-bus address

- Go up to «U» in the menu
- Hold the key pressed ( $\geq 3$  sec.)  $\rightarrow$  «SBUS-ADR»
- Press the key briefly  $\rightarrow$  S-busaddress +1, keep the key depressed  $\rightarrow$  S-busaddress +10
- Once the desired address has been reached, wait until the principal display reappears

## Registers

The following registers are available. The registers 4, 10, 11, 13, 18, 22 and 23 are not used, and a 0 is always issued.

R	Reading	Writing	Description	Values
0	X		Firmware version	Ex: «11» = FW 1.1
1	X		Number of supported registers	Issues «29»
2	X		Number of supported flags	Issues «0»
3	X		Baud rate	BPS
4	X		Not used	Issues «0»
5	X		Type/ASN function	Issues «ALD1»
6	X		Type/ASN function	Issues «B5FS»
7	X		Type/ASN function	Issues «00A»
8	X		Type/ASN function	Issues « »
9	X		HW version modif	Ex: «11» = FW 1.1
10	X		Not used	Issues «0»
11	X		Not used	Issues «0»
12	X		Serial number	Issues «0»
13	X		Not used	
14	X		Status/Protect	«0» = no problem «1» = problems with the last communication query
15	X		S-bus time-out	ms
16	X	X	S-bus address	
17	X		Flags error	0: No errors                      1: Error(s)
18	X		Not used	Issues «0»
19	X		Energy direction register	0 = energy direction «consumption» 4= energy direction «feeding back»
20	X		Counter total «energy consumption»	10 <sup>-2</sup> kWh. (multiplier 0.01) Example: 00912351= 009123.51 kWh
21	X		Counter total «energy feedback»	10 <sup>-2</sup> kWh. (multiplier 0.01) Example: 00912351= 009123.51 kWh
22	X		Not used	Issues «0»
23	X		Not used	Issues «0»
24	X		Effective value, voltage	V Example: 230 = 230 V
25	X		Effective value, current	10 <sup>-1</sup> A (multiplier 0.1) Example: 314 = 31.4 A
26	X		Effective value, active power	positive: Energy «→» negative: Energy «←» 10 <sup>-2</sup> kW (multiplier 0.01) Example: 1545 = 15.45 kW
27	X		Effective value, idle power	10 <sup>-2</sup> kVar (multiplier 0.01) Example: 1545 = 15.45 kVAr
28	X		Cos phi	10 <sup>-2</sup> (multiplier 0.01) Example: 67 = 0.67

### Connection diagram / Method of operation

Energy is added as indicated by the arithmetic operator. Positive output in the meter indicates that energy is being supplied, while negative output indicates that energy is being delivered.

If the supply of energy (P positive) is greater than the delivery of energy (P negative), the count register  $T \rightarrow$  increases.

The LCD segment «2000 pulses/kWh» is OFF and only switches on if there is a pulse.

If the delivery of energy is greater than the supply of energy, the count register  $T \leftarrow$  increases.

The LCD segment «2000 pulses/kWh» is ON and only switches off if there is a pulse.

### Method of operation with direction of current «supply $\rightarrow$ »

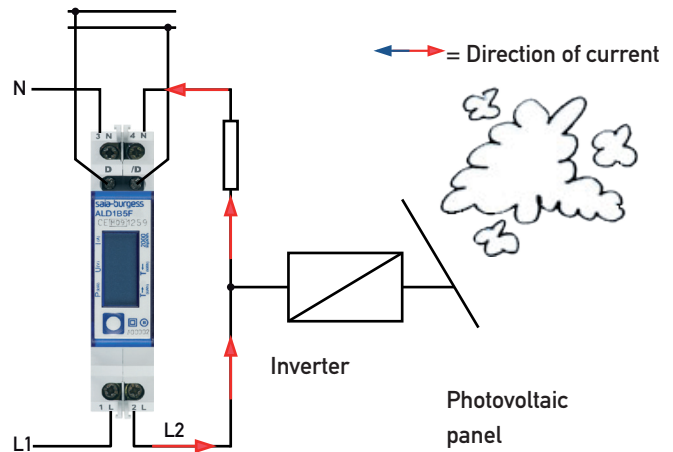
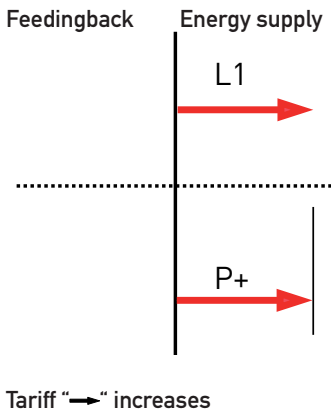

### Method of operation with direction of current «feeding back $\leftarrow$ »

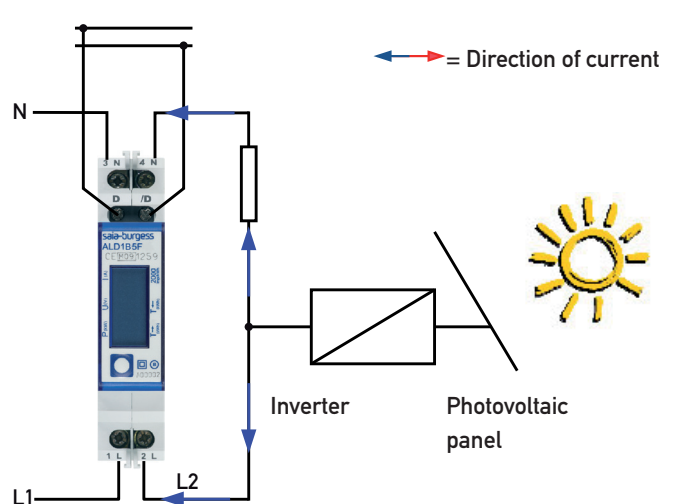
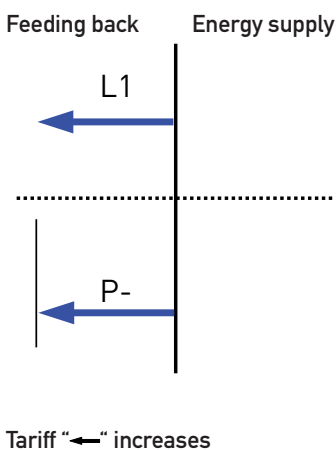



## Contact

---

Switzerland and international

Saia-Burgess Controls AG  
Bahnhofstrasse 18  
CH-3280 Murten / Switzerland  
T +41 (0)26 672 72 72  
F +41 (0)26 672 74 99  
pcd@saia-burgess.com  
www.saia-pcd.com

Supplied by:

---

Product Support,  
Technical reference website:

[www.saia-support.com](http://www.saia-support.com)